

PRÁCTICABLE
SERIE PT-70 ÓPTIMA



ALUMINIOS AFESA, S.L.
ALMACÉN DE PERFILES



CARACTERÍSTICAS TÉCNICAS

Serie PT-70 Óptima

Serie practicable con rotura de puente térmico con canal europeo para alojamiento de herrajes.

Perfiles ensamblados con doble varilla de poliamida reforzada con fibra de vidrio de 24mm de ancho en cerco y hoja.

Ensamblaje de perfiles con escuadras de bloqueo mecanizadas.

Anchos de cerco de 72mm y hoja de 74mm.

Variantes estéticas con formas rectas, curvas o con forma de elipse.

Gama de acristalamiento desde 15 hasta 40 mm.

Posibilidad de acabados en bicolor.





PRESTACIONES

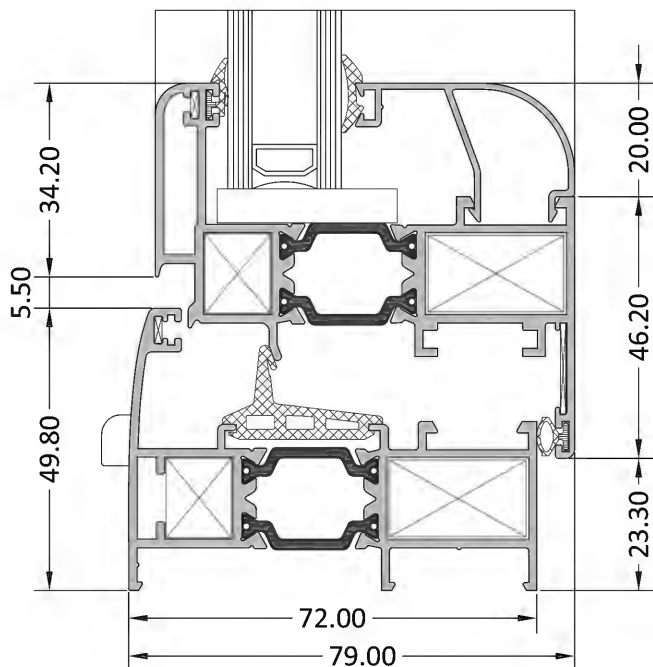

RESULTADOS DE ENSAYOS

Permeabilidad al aire	CLASE 4	Permeabilidad al aire	CLASE 4
Estanqueidad al agua	CLASE E1200	Estanqueidad al agua	CLASE E750
Resistencia a la carga de viento	CLASE C4	Resistencia a la carga de viento	CLASE C2
Aislamiento acústico R_w (C;Ctr)	33 (-2,-5) dB		
Transmitancia térmica U_w	3,1 W/(m ² K)		

Resultados de ensayo de ventana de dos hojas de 1230 (ancho) x 1480 (alto) con cajón de persiana con vidrio tipo 6-12-6.

Resultados de ensayo de puerta balconera de dos hojas de 1500 (ancho) x 2100 (alto) con cajón de persiana con vidrio tipo 6-12-6.

CÁLCULOS TÉRMICOS

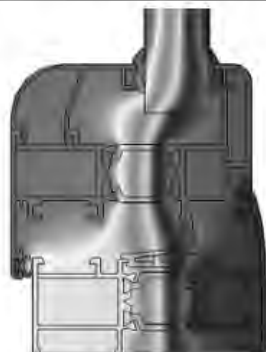

3800-13805 $U_{marco} = 3.3 \text{ W/m}^2\text{K}$

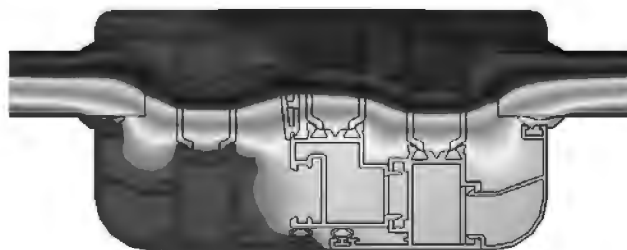

13805-3809-13805 $U_{marco} = 3.3 \text{ W/m}^2\text{K}$

TRANSMITANCIA TÉRMICA U_w PARA DIFERENTES VIDRIOS SEGÚN NORMA UNE-EN ISO 10077-1

$U_w = 2.2 \text{ W/m}^2\text{K}$
 $U_g = 1.0 \text{ W/m}^2\text{K}$
Cálculo unidad de 1.23 ancho x 1.48 alto

$U_w = 2.0 \text{ W/m}^2\text{K}$
 $U_g = 1.0 \text{ W/m}^2\text{K}$
Cálculo unidad de 1.50 ancho x 2.10 alto





PERFILES

3874

CERCO DE VENTANA

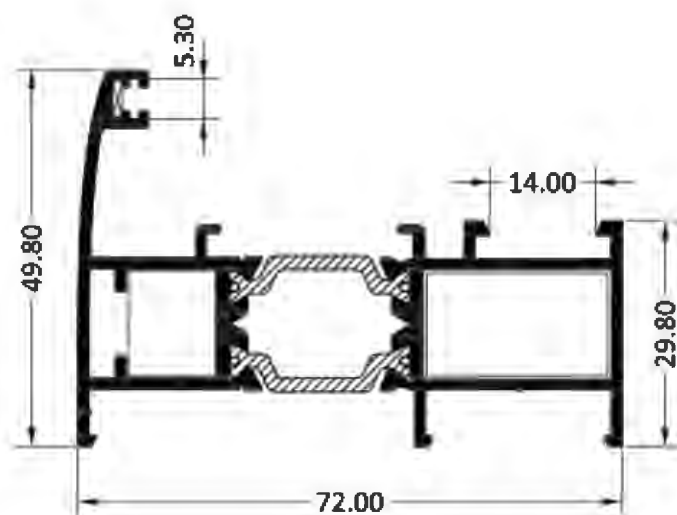

3883

CERCO DE PUERTA DE 67 mm.

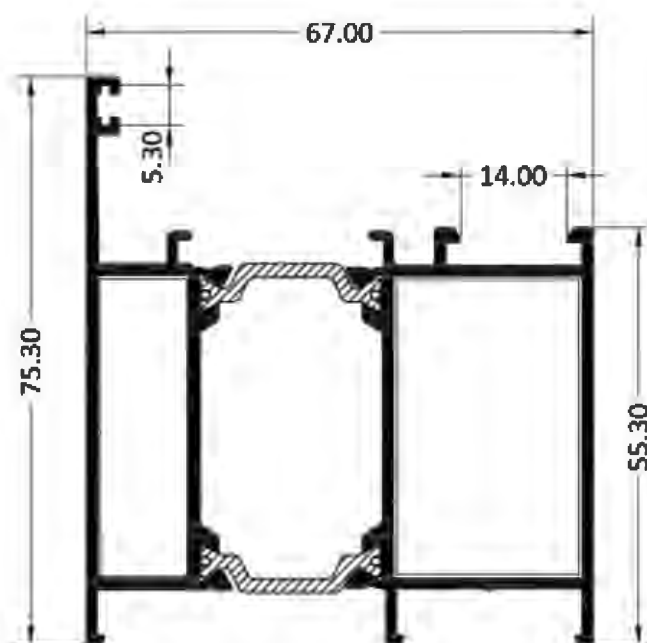



PERFILES

3875
HOJA CURVA

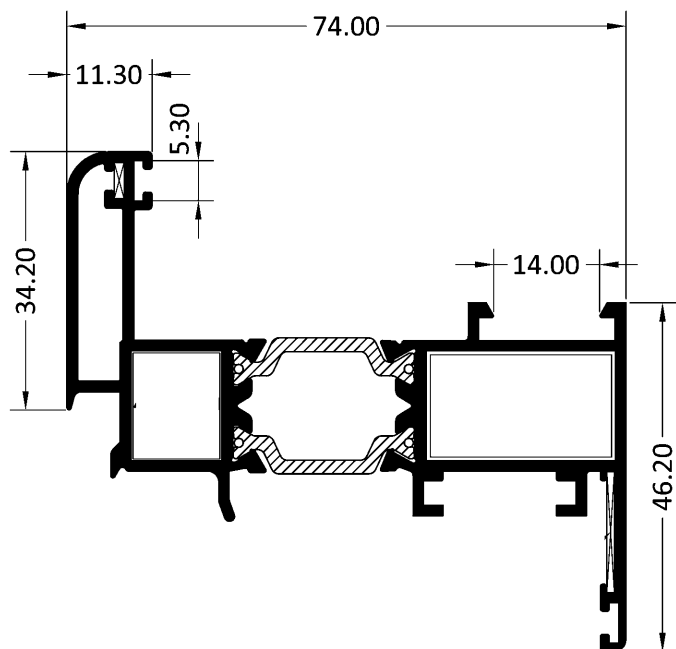

3876
INVERSOR RECTO

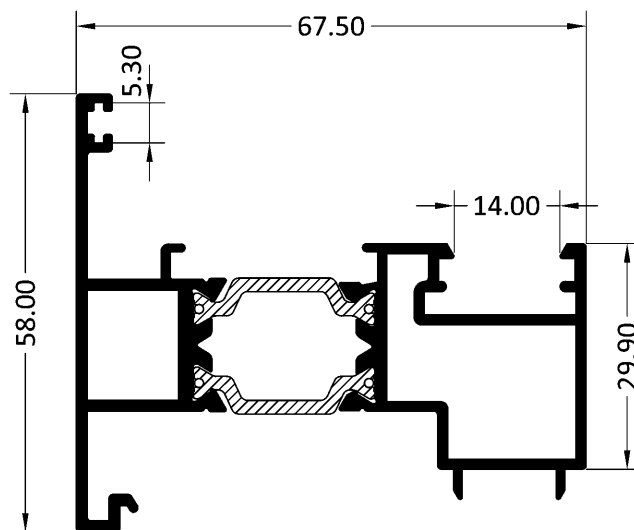

3884
HOJA CURVA PUERTA

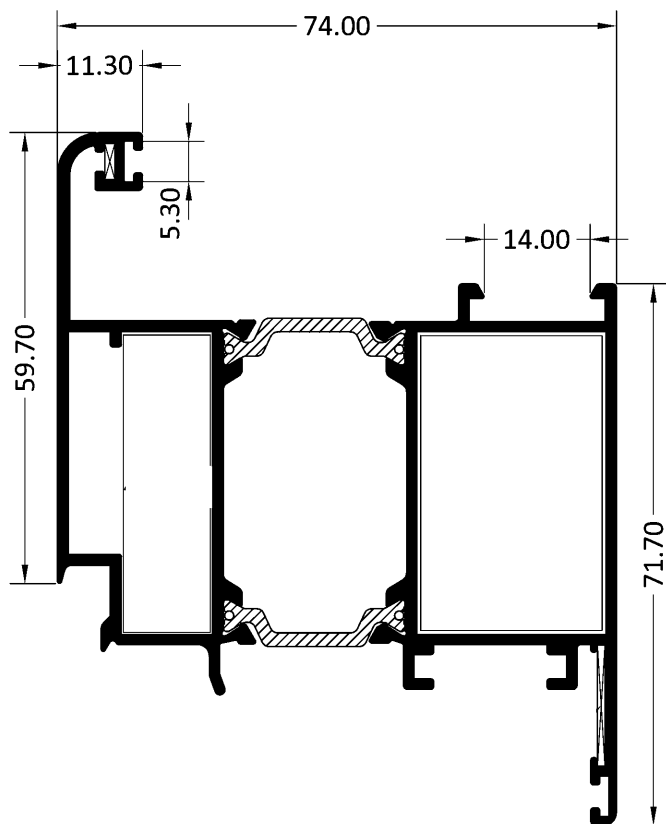

3885
HOJA CURVA PUERTA APERTURA EXTERIOR

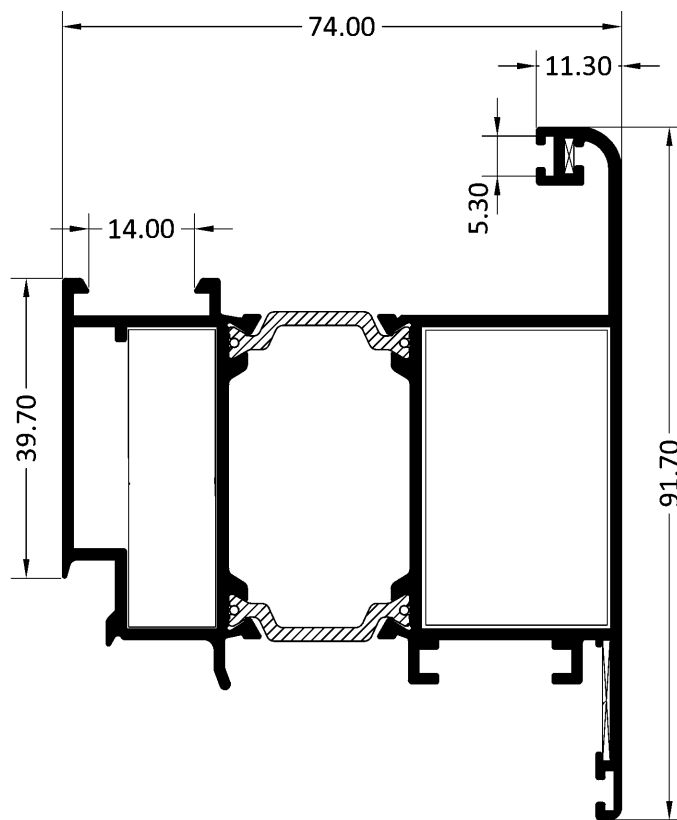



PERFILES

3881
TRAVESAÑO 90 mm

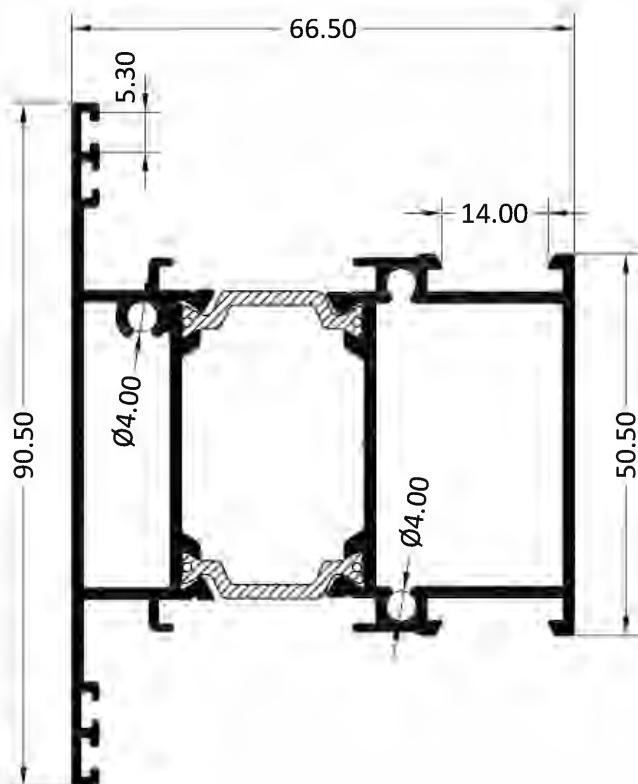

3879
TRAVESAÑO 67 mm

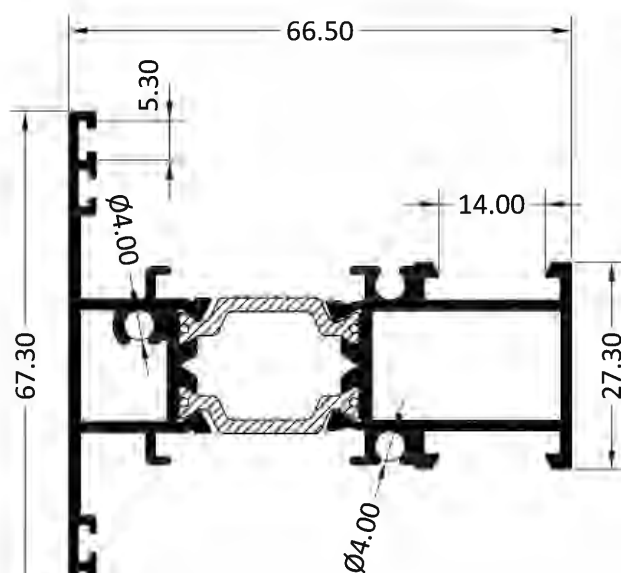

3814
SOLAPE CLIP 45 mm

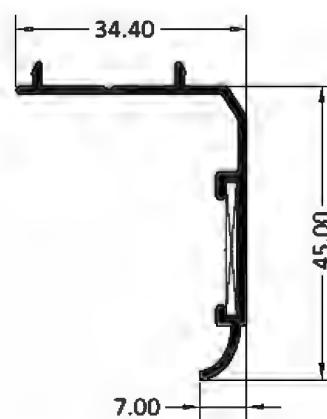

3860
ESQUINERO

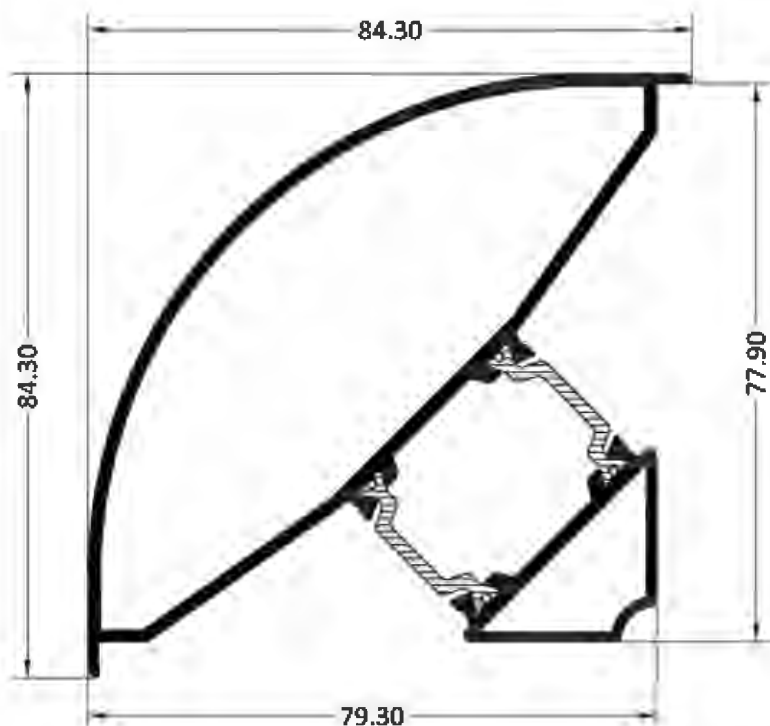

5275
SOLAPE GUÍA 45 mm

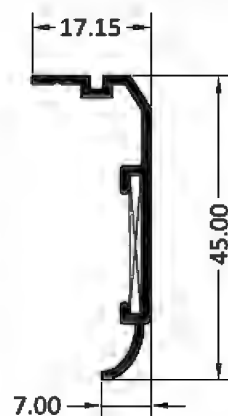



PERFILES

3863

TRAVESAÑO 140 mm CERCO PUERTA

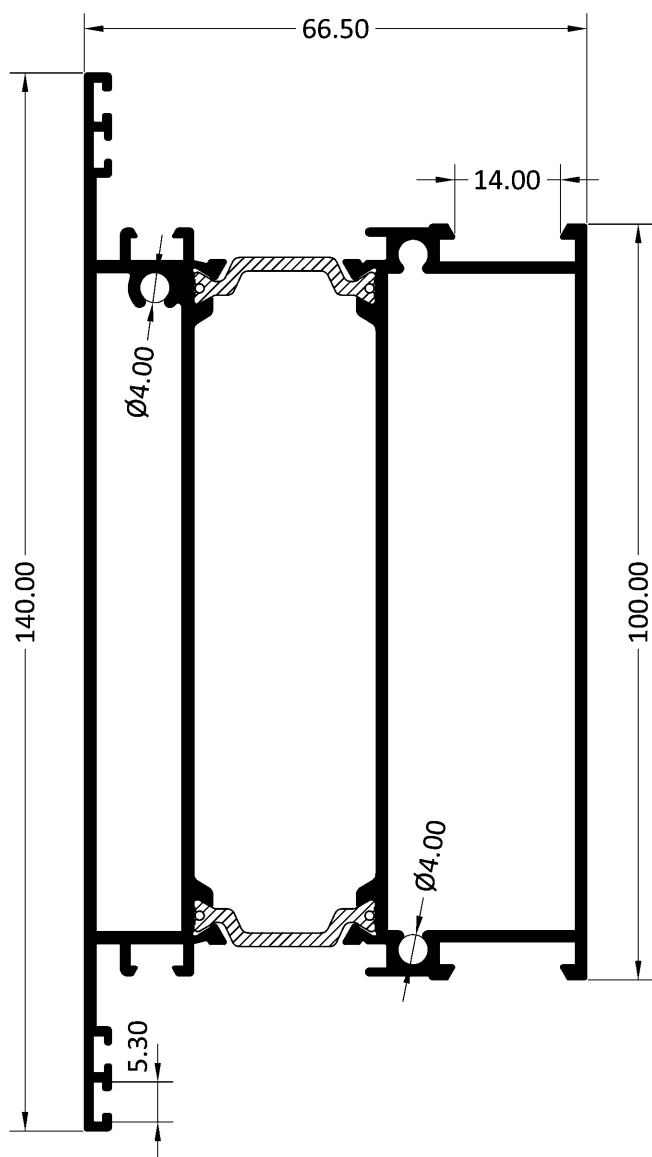

3865

ZÓCALO 140 mm CERCO

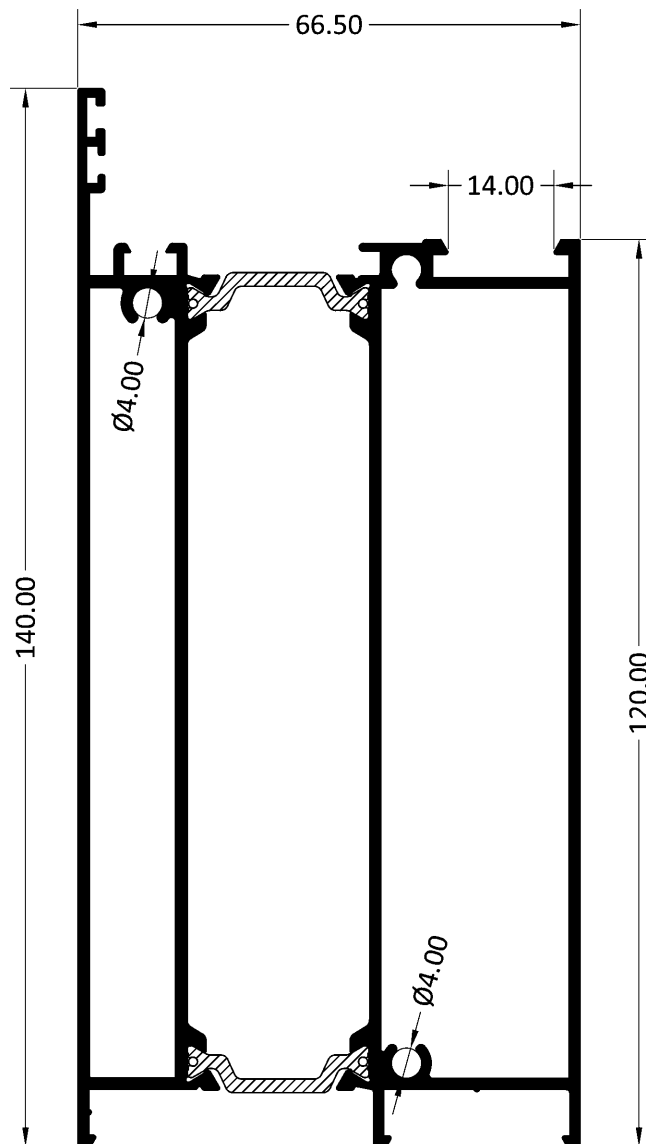

3872

UNIÓN DE CERCOS DE 72 mm

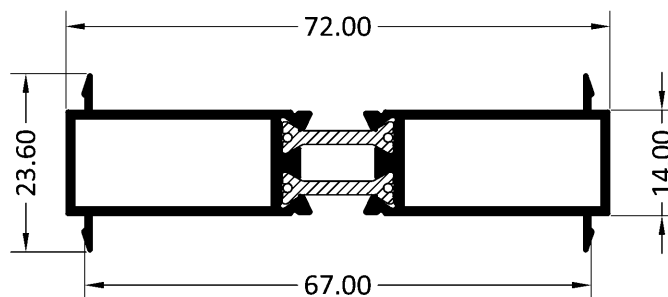



ACRISTALAMIENTO

REFERENCIA	DENOMINACIÓN	SECCIÓN	HUECO	VIDRIO
3832	Junquillo recto clipado de 18.00		44.70	40 - 35
3821	Junquillo curvo clipado de 18.40		44.30	40 - 35
3822	Junquillo curvo con grapa de 18.40			
3826	Junquillo recto clipado de 22.40		40.30	36 - 31
3834	Junquillo curvo con grapa de 22.40			
3835	Junquillo curvo clipado de 22.40			
3833	Junquillo curvo con grapa de 26.40		36.30	32 - 27
3836	Junquillo curvo clipado de 26.40			
3857	Junquillo curvo con grapa de 27.40		35.30	31 - 26
3856	Junquillo curvo con grapa de 33.40		29.30	25 - 20
3861	Junquillo curvo clipado de 33.40			
3880	Junquillo recto clipado de 36.70		26.00	22 - 17
3870	Junquillo curvo clipado de 38.70		24.00	20 - 15
3871	Junquillo curvo con grapa de 38.70			



LISTA DE CORTE - VENTANA DE DOS HOJAS

ALZADO

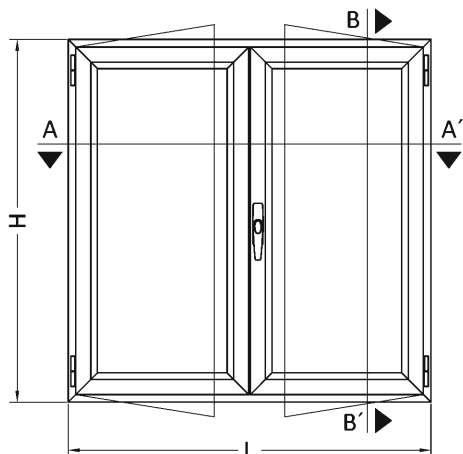

SECCIÓN VERTICAL B-B'

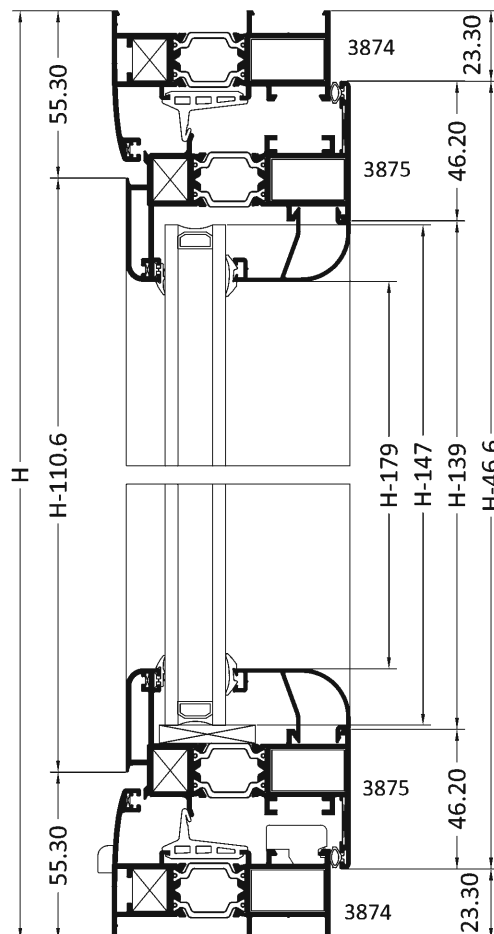

PERFIL	DENOMINACIÓN	UDS	CORTE
3874	Cerco	2	L
3874	Cerco	2	H
3875	Hoja curva	4	L/2-25.8
3875	Hoja curva	4	H-46.6
3876	Inversor recto	1	H-110.6
(*)	Junquillo	4	L/2-118.2
(*)	Junquillo	4	H-179

(*) Para la elección de junquillo consultar tabla de acristamiento

SECCIÓN HORIZONTAL A-A'

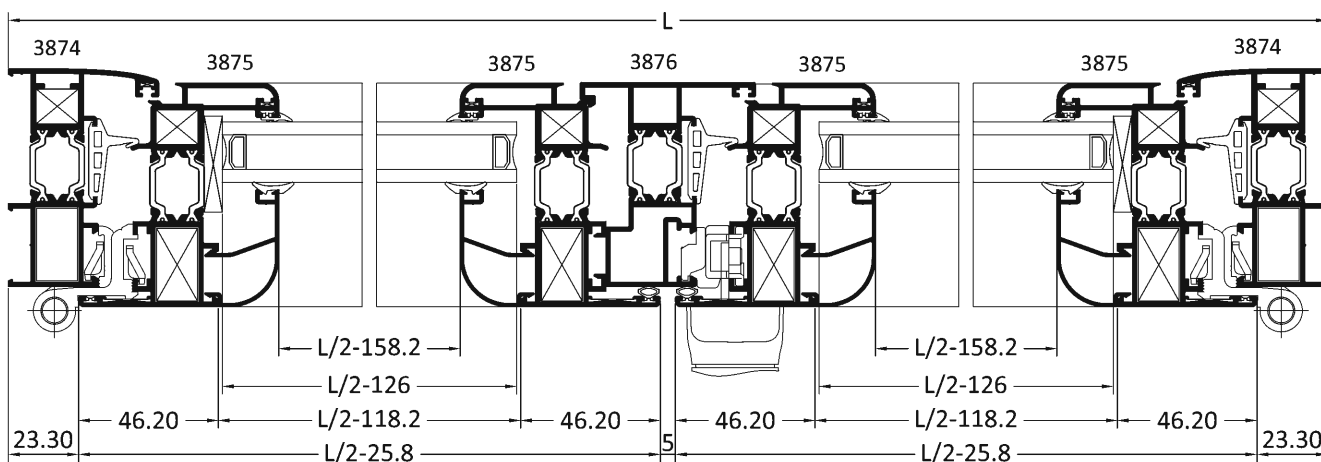

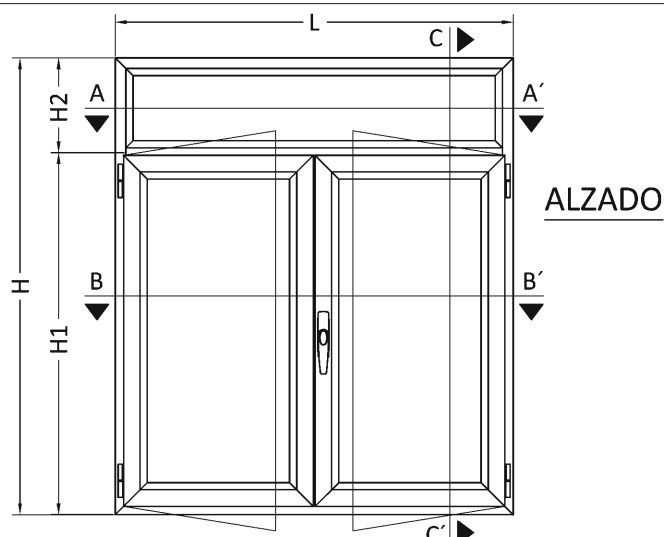
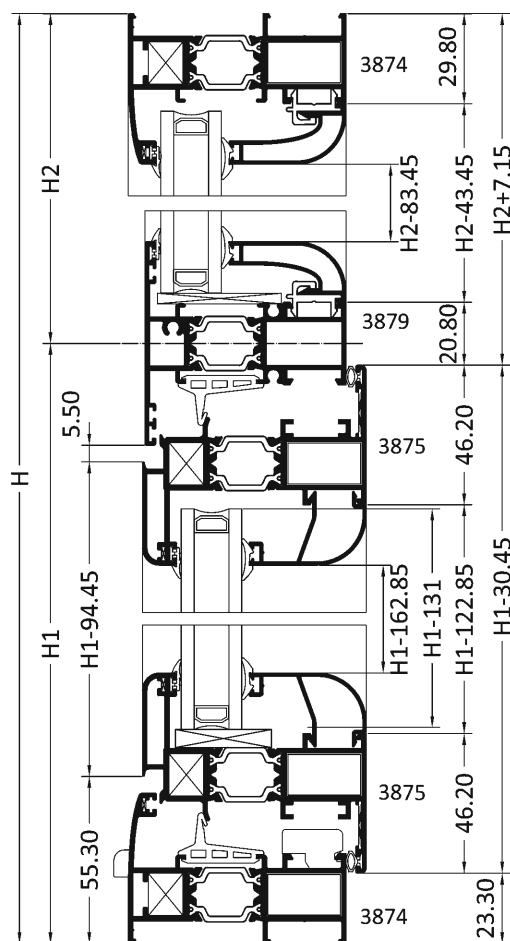
LISTA DE CORTE - VENTANA DE DOS HOJAS CON FIJO SUPERIOR

SECCIÓN VERTICAL C-C'

PERFIL	DENOMINACIÓN	UDS	CORTE
3874	Cerco	2	L
3874	Cerco	2	H
3879	Travesaño 67	1	L-59.6
3875	Hoja curva	4	L/2-25.8
3875	Hoja curva	4	H1-30.45
3876	Inversor recto	1	H1-94.45
(*)	Junquillo hoja	4	L/2-118.2
(*)	Junquillo hoja	4	H1-162.85
(*)	Junquillo fijo	2	L-59.6
(*)	Junquillo fijo	2	H2-83.45

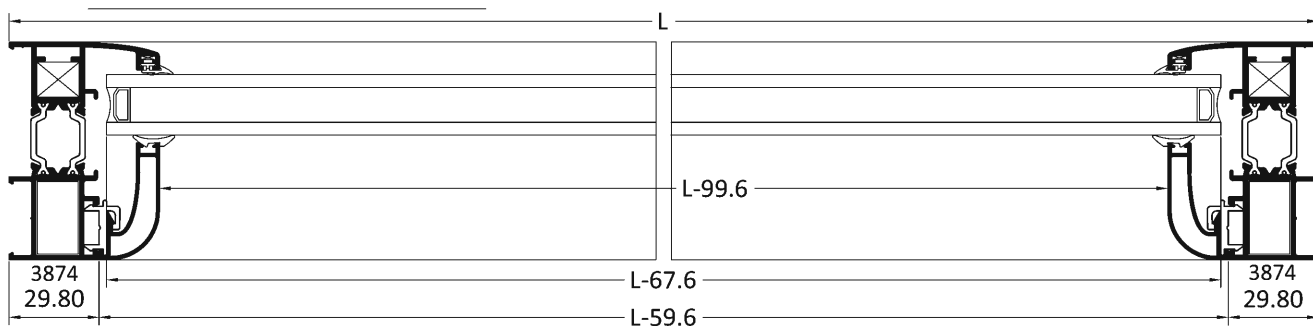
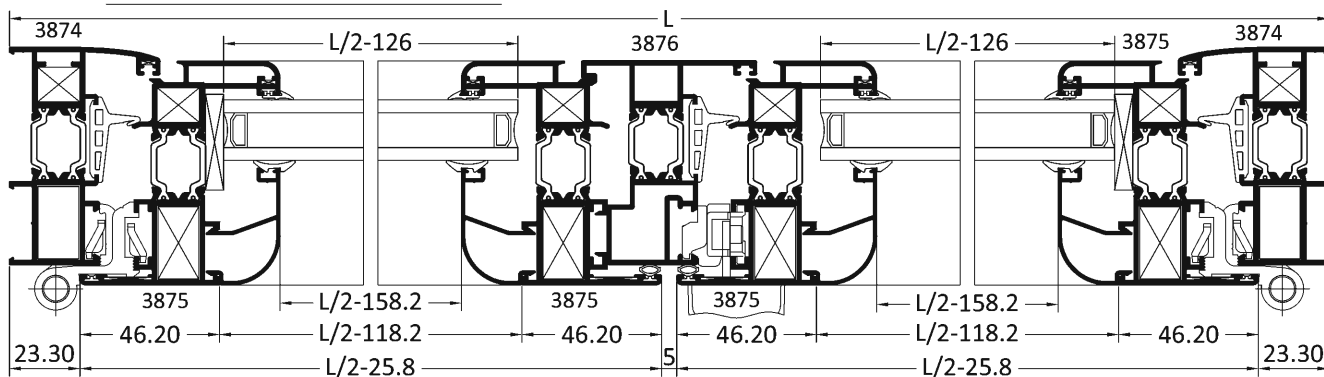
(*) Para la elección de junquillo consultar tabla de acristalamiento

SECCIÓN HORIZONTAL A-A'

SECCIÓN HORIZONTAL B-B'

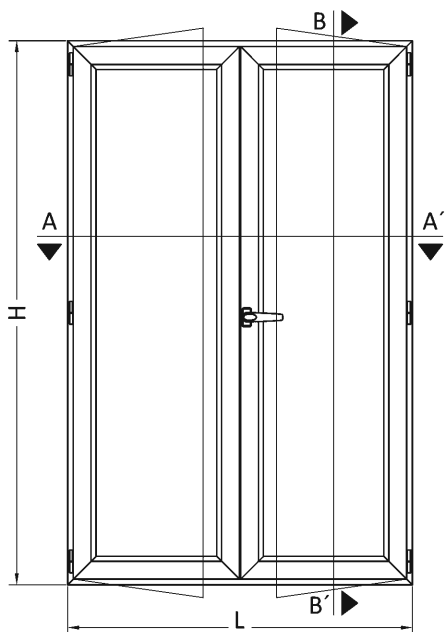

LISTA DE CORTE - BALCONERA DE DOS HOJAS APERTURA INTERIOR

ALZADO



SECCIÓN VERTICAL B-B'

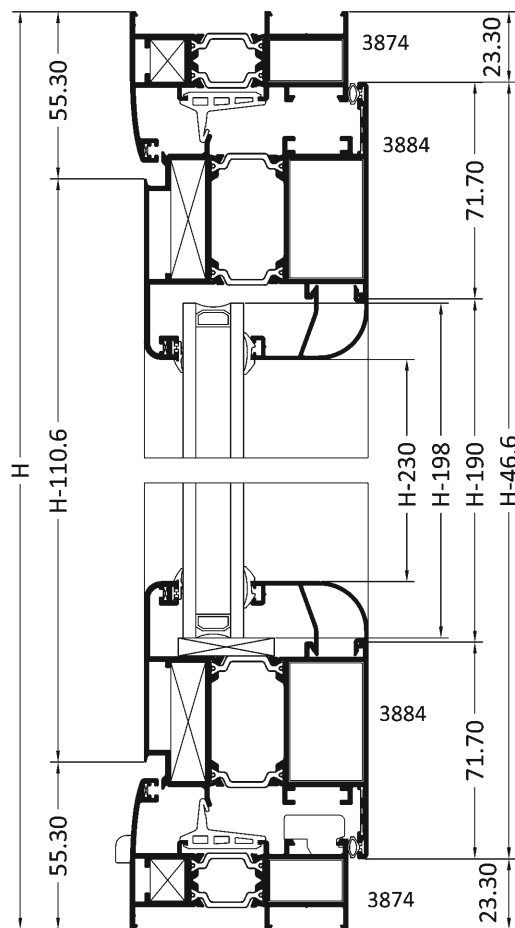

PERFIL	DENOMINACIÓN	UDS	CORTE
3874	Cerco	2	L
3874	Cerco	2	H
3884	Hoja curva puerta	4	L/2-25.8
3884	Hoja curva puerta	4	H-46.6
3876	Inversor recto	1	H-110.6
(*)	Junquillo	4	L/2-169.2
(*)	Junquillo	4	H-190

(*) Para la elección de junquillo consultar tabla de acristalamiento

SECCIÓN HORIZONTAL A-A'

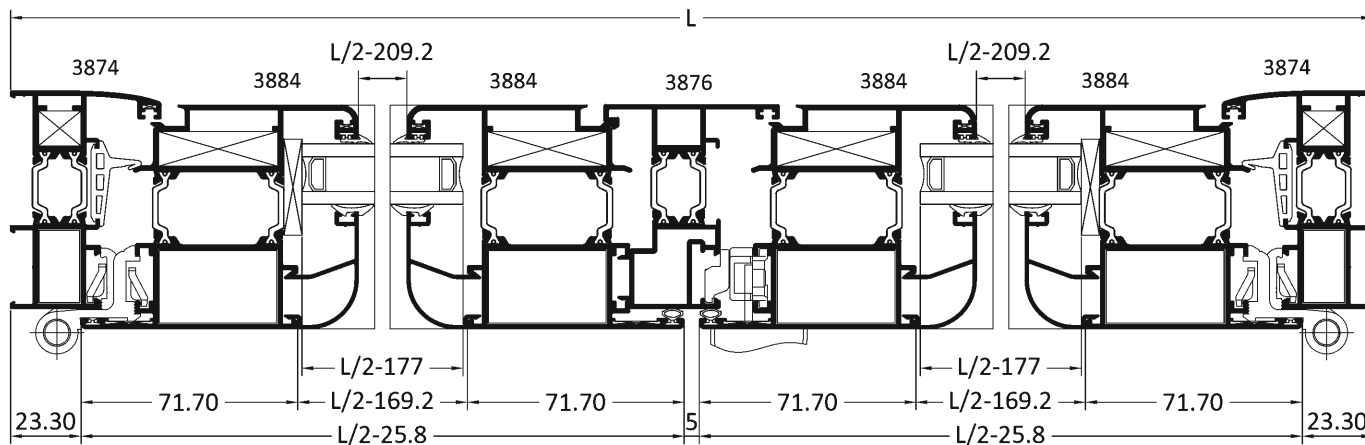



LISTA DE CORTE - PUERTA DE DOS HOJAS APERTURA EXTERIOR

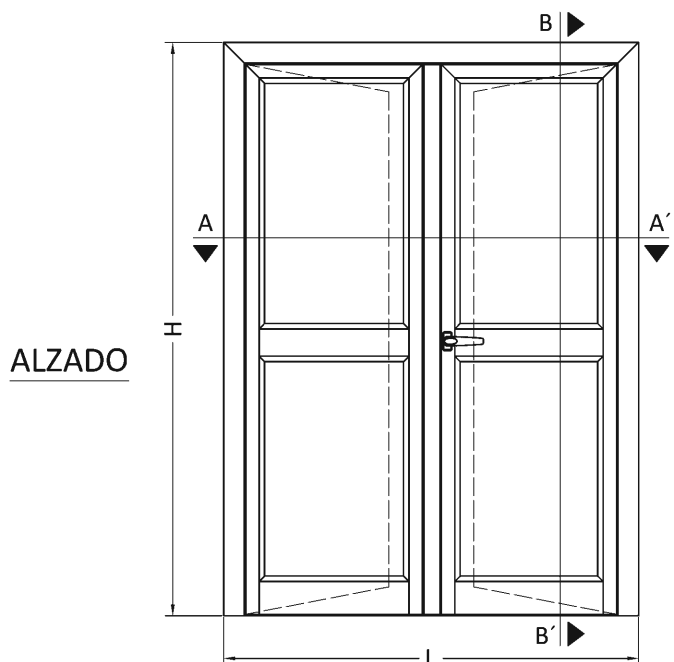

SECCIÓN VERTICAL B-B'

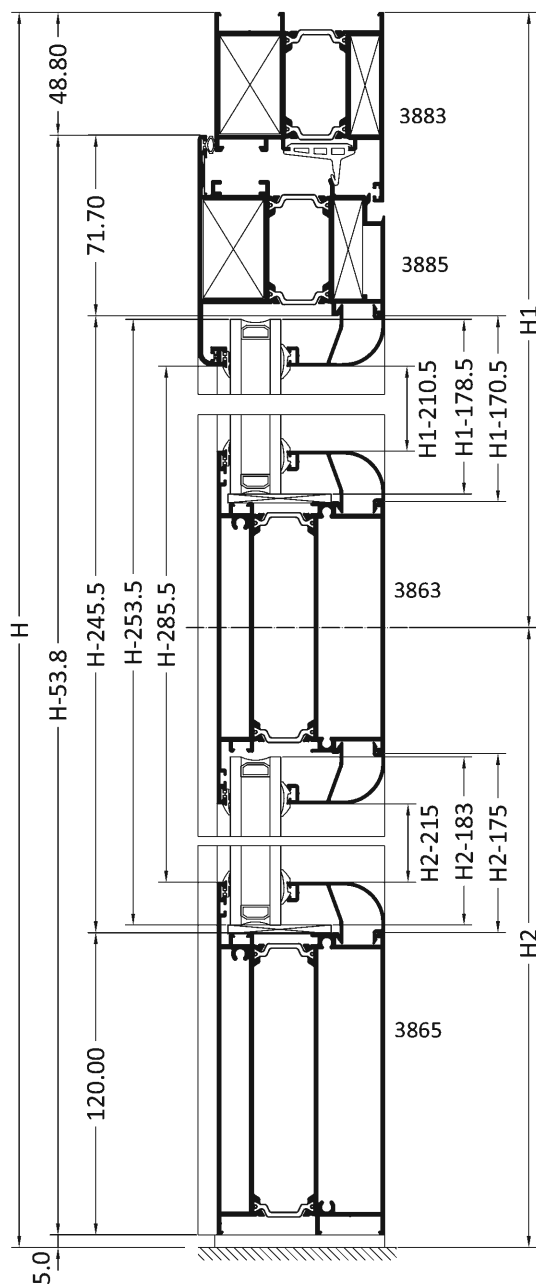

PERFIL	DENOMINACIÓN	UDS	CORTE
3883	Cerco de puerta	1	L
3883	Cerco de puerta	2	H
3885	Hoja elipse puerta apertura exterior	2	L/2-51.3
3885	Hoja elipse puerta apertura exterior	4	H-53.8
3876	Inversor recto	1	H-80.8
3863	Travesaño 140	2	L/2-213.7
3865	Zócalo 140	2	L/2-213.7
(*)	Junquillo horizontal	8	L/2-213.7
(*)	Junquillo vertical H1	4	H1-220
(*)	Junquillo vertical H2	4	H2-215

(*) Para la elección de junquillo consultar tabla de acristalamiento

SECCIÓN HORIZONTAL A-A'

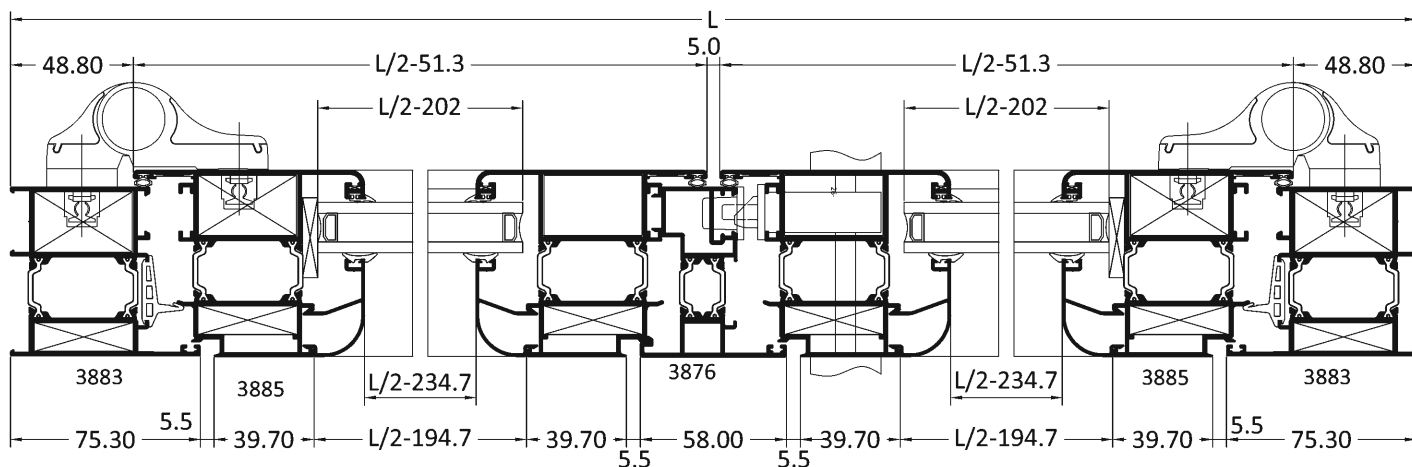







RELACION DE ACCESORIOS

Artículo	Imagen	Descripción
300022		Escuadra de bloqueo de 25 x 14.5
300001		Escuadra de bloqueo de 25 x 40
300002		Escuadra de bloqueo ventana 12x14
300113		Escuadra de bloqueo puerta 12x40
ESHOJA		Escuadra de alineamiento interior hoja
ESSOLAPE		Escuadra de alineamiento tapajuntas
4078PA		Grapa para junquillo
0070TIR		Tapa inversor recto 3876
4035		Tapa Salida Aguas
300330		Junta central

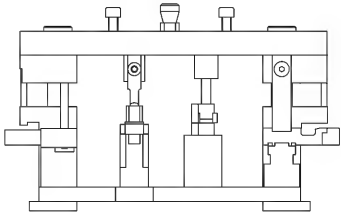

RELACION DE ACCESORIOS

Artículo	Imagen	Descripción
309047		Junta perimetral de hoja
300017		Anclaje jamba
141814UC		Unión travesaño
361814U		Unión travesaño
300015		Troquel PT-70 Óptima