

## CARACTERÍSTICAS TÉCNICAS

### Serie CPT-110E

Serie corredera elevable con rotura de puente térmico pensada para cerramientos de grandes superficies.

Perfiles ensamblados con doble varilla de poliamida reforzada con fibra de vidrio de 24mm de ancho en cerco y 14,8mm en hoja.

Ensamblaje de perfiles con escuadras de bloqueo mecanizadas.

Anchos de cerco de 110mm para dos carriles y de 105mm para cercos de una hoja corredera con fijo.

Hoja de 45mm. compatible con los perfiles complementarios y junquillos de la serie PT-50.

El herraje permite la realización de hojas de hasta 300 kg. de peso.

Gama de acristalamiento desde hasta 36mm.

Posibilidad de acabados en bicolor.

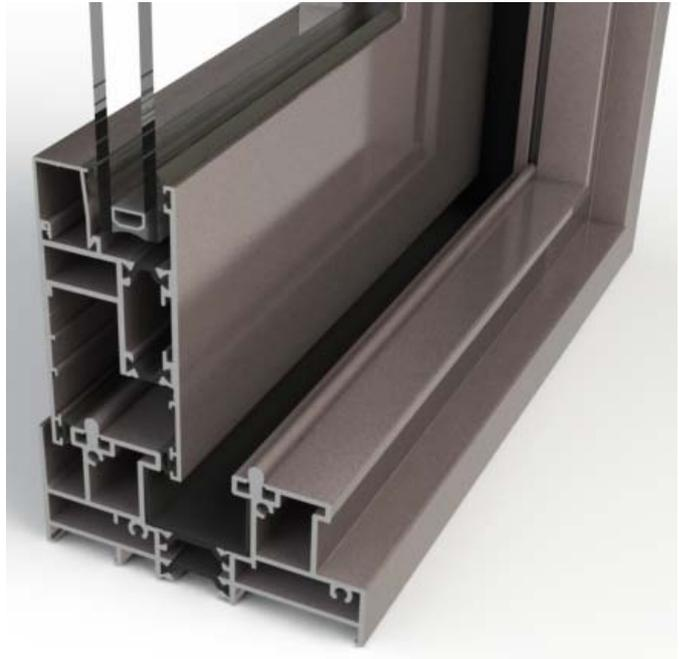
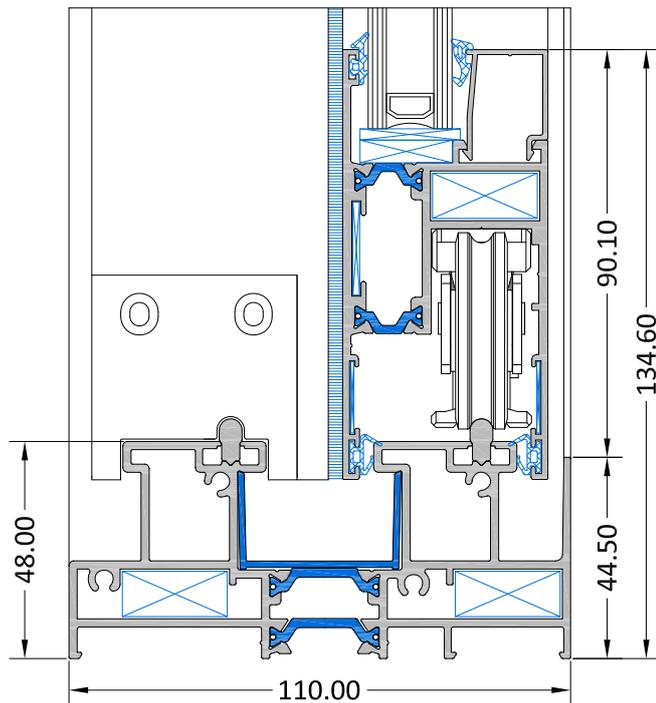

**RESULTADOS DE ENSAYOS**

Permeabilidad al aire	CLASE 2
Estanqueidad al agua	CLASE 7A
Resistencia a la carga de viento	CLASE C1/B2

**CÁLCULOS TÉRMICOS UNE-EN ISO 10077-1:2010**

Vidrio Ug (w/m <sup>2</sup> K)	Uw (w/m <sup>2</sup> K)
3,2	3,7
2,8	3,4
2,0	2,8
1,6	2,5
1,1	2,1
1,0	2,0
0,7	1,8

**AISLAMIENTO ACÚSTICO**

Tipo de vidrio (dB)	Aislamiento acústico para la ventana (dB) y según superficie de muestra (m <sup>2</sup> )			
	Área total ≤ 2,7 m <sup>2</sup>	2,7 m <sup>2</sup> < Área total ≤ 3,6 m <sup>2</sup>	3,6 m <sup>2</sup> < Área total ≤ 4,6 m <sup>2</sup>	4,6 m <sup>2</sup> < Área total
27	25 (-1;0)	24 (-1;0)	23 (-1;0)	22 (-1;0)
28	26 (-1;0)	25 (-1;0)	24 (-1;0)	23 (-1;0)
29	27 (-1;-2)	26 (-1;-2)	25 (-1;-2)	24 (-1;-2)
30	28 (-1;-1)	27 (-1;-1)	26 (-1;-1)	25 (-1;-1)
32	29 (-1;-2)	28 (-1;-2)	27 (-1;-2)	26 (-1;-2)
34	29 (-1;-2)	28 (-1;-2)	27 (-1;-2)	26 (-1;-2)
36	30 (-1;-3)	29 (-1;-3)	28 (-1;-3)	27 (-1;-3)

Resultados de ensayos de ventana de dos hojas de 3000 (ancho) x 2400 (alto) con vidrio tipo 3+3-10-5.

20800

Marco perimetral

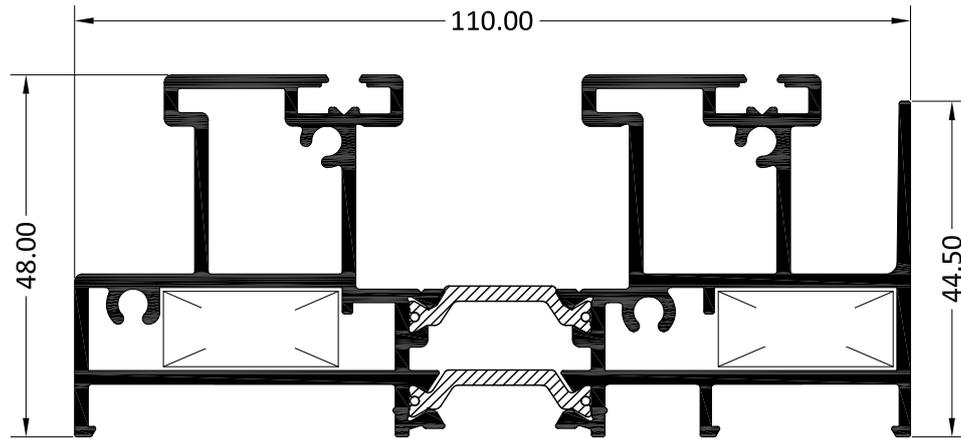

20802

Marco fijo

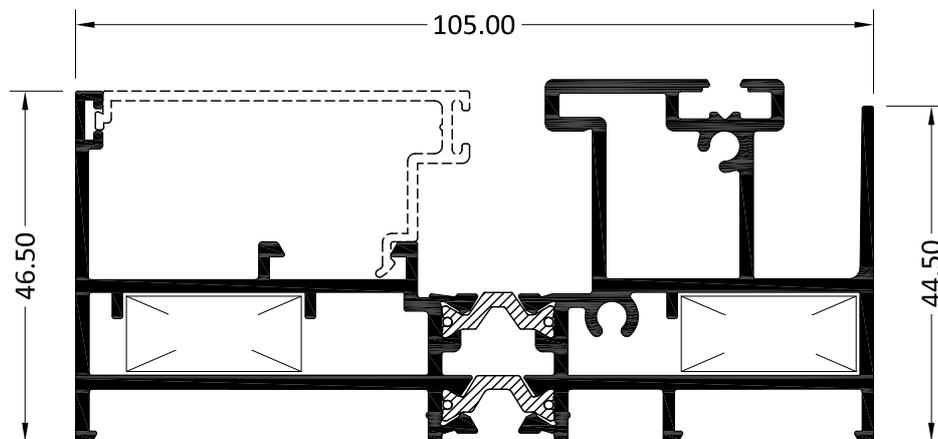

20803

Marco tres carriles

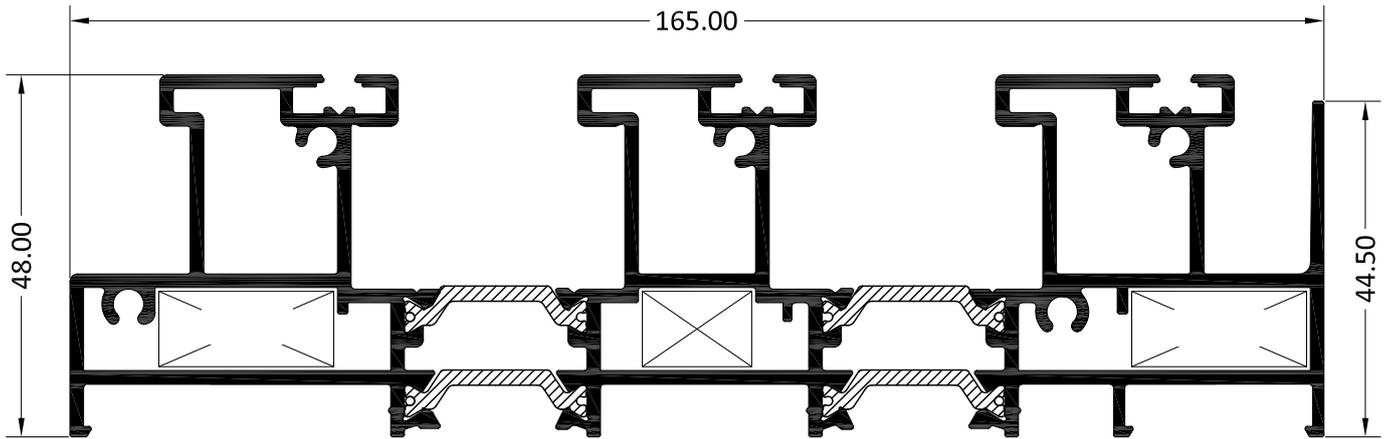

20801

Hoja perimetral

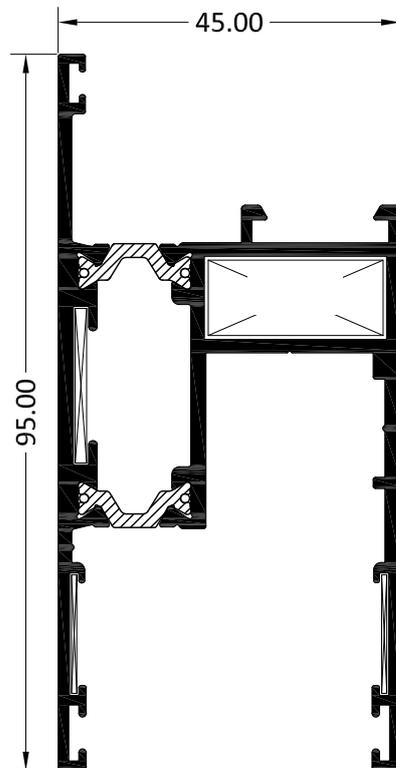

20804

Cierre 4 hojas

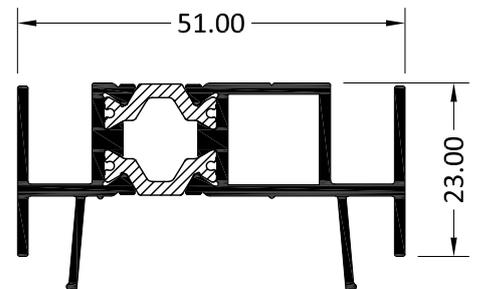

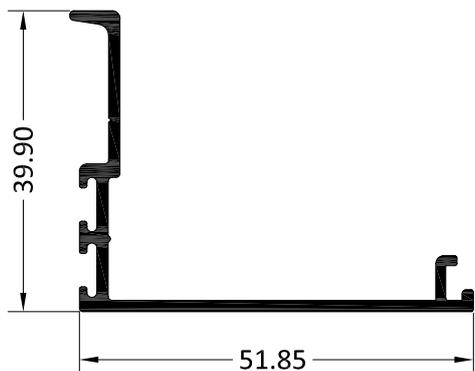
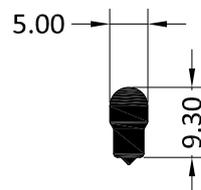
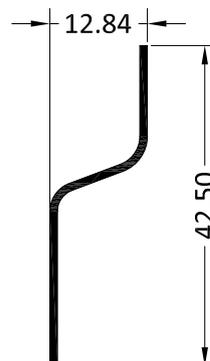
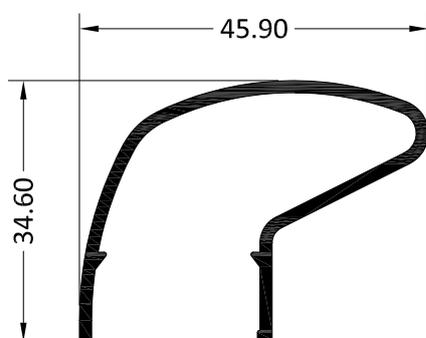
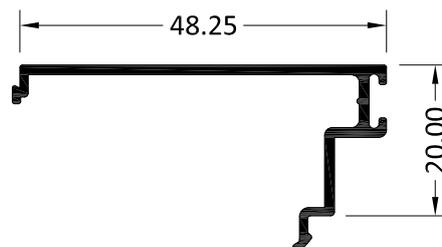
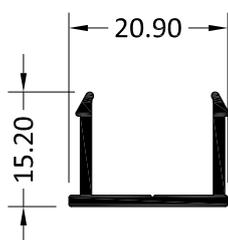
**85304** Perfil de cruce

**85305** Carril rodadura

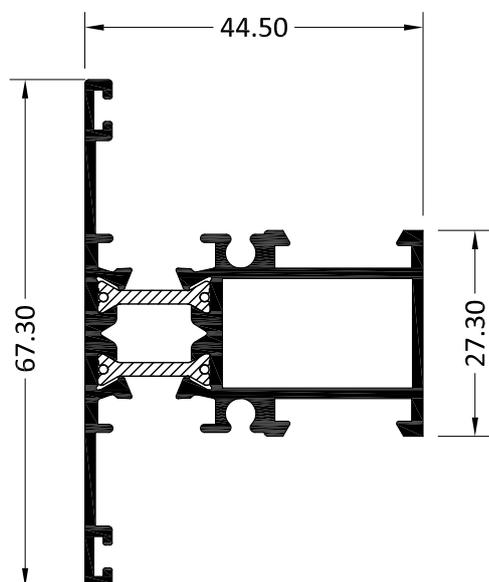
**3704** Visera

**3763** Tirador

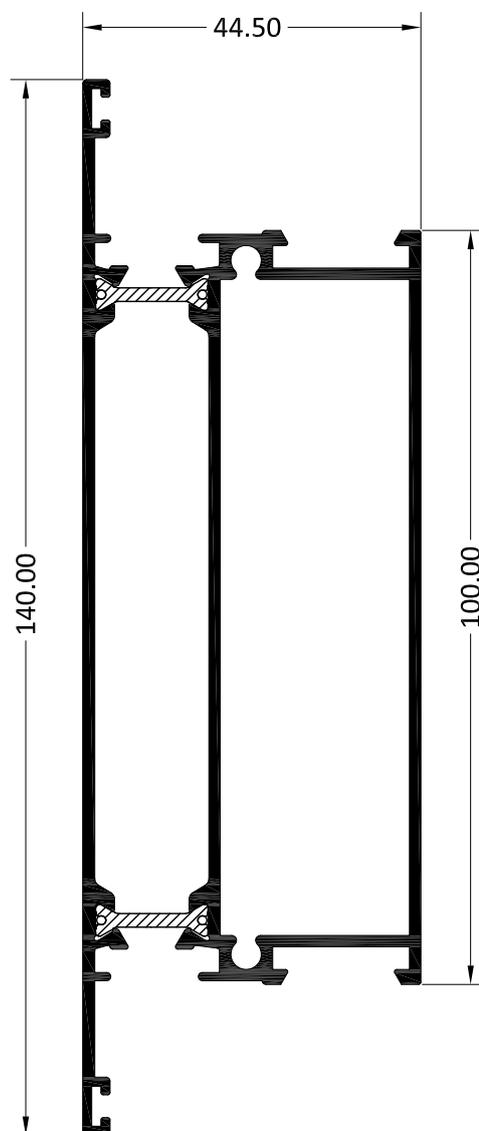
**85307** Junquillo para marco fijo

**3764** Base Tirador

**3808**  
TRAVESAÑO 67 mm



**3843**  
TRAVESAÑO 140 mm



**3825**  
TRAVESAÑO 90 mm

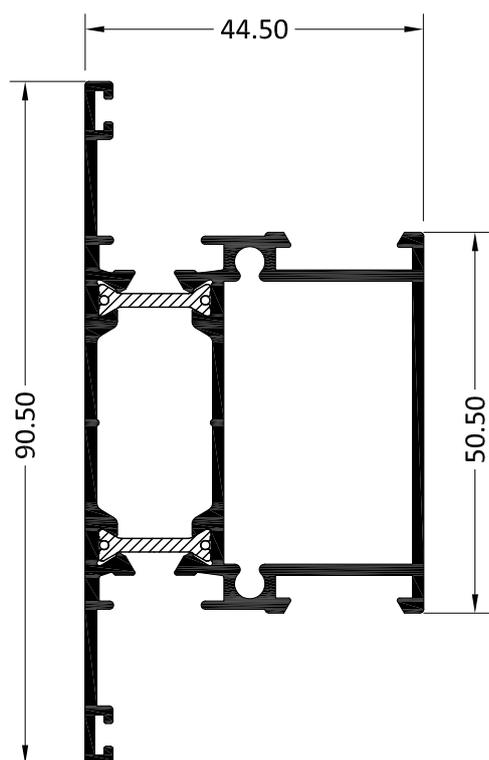

LISTA DE CORTE. PUERTA DE DOS HOJAS. UNA HOJA FIJA Y UNA HOJA ELEVABLE

ALZADO

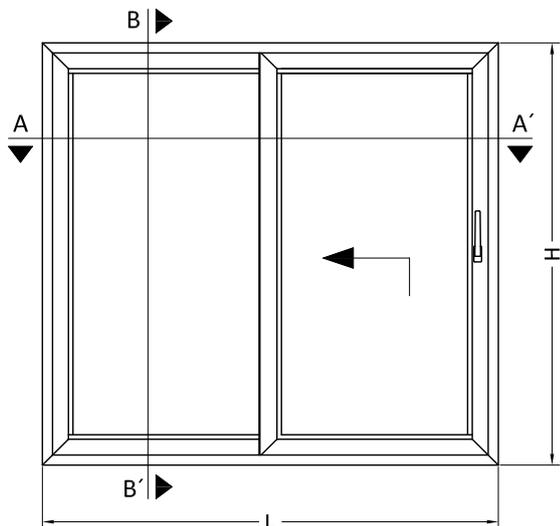

SECCIÓN VERTICAL B-B'

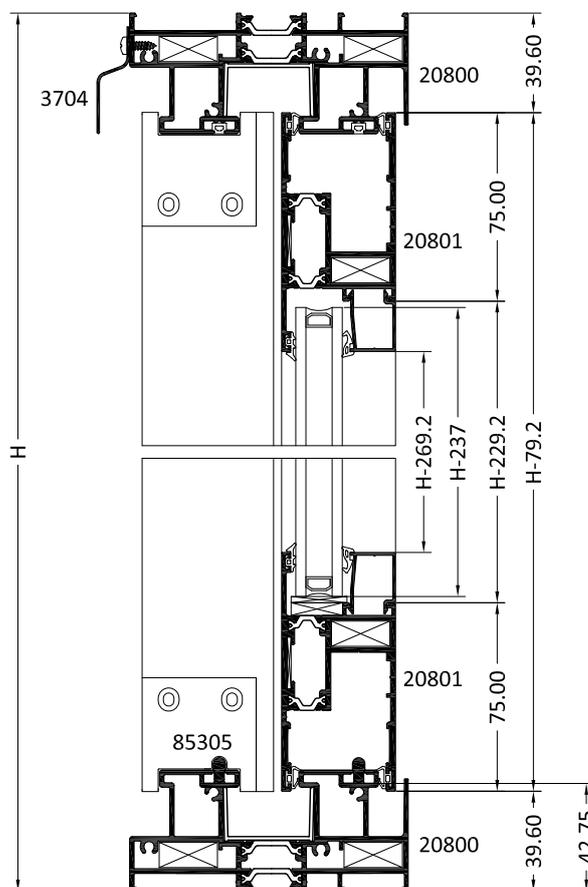

SECCIÓN HORIZONTAL A-A'

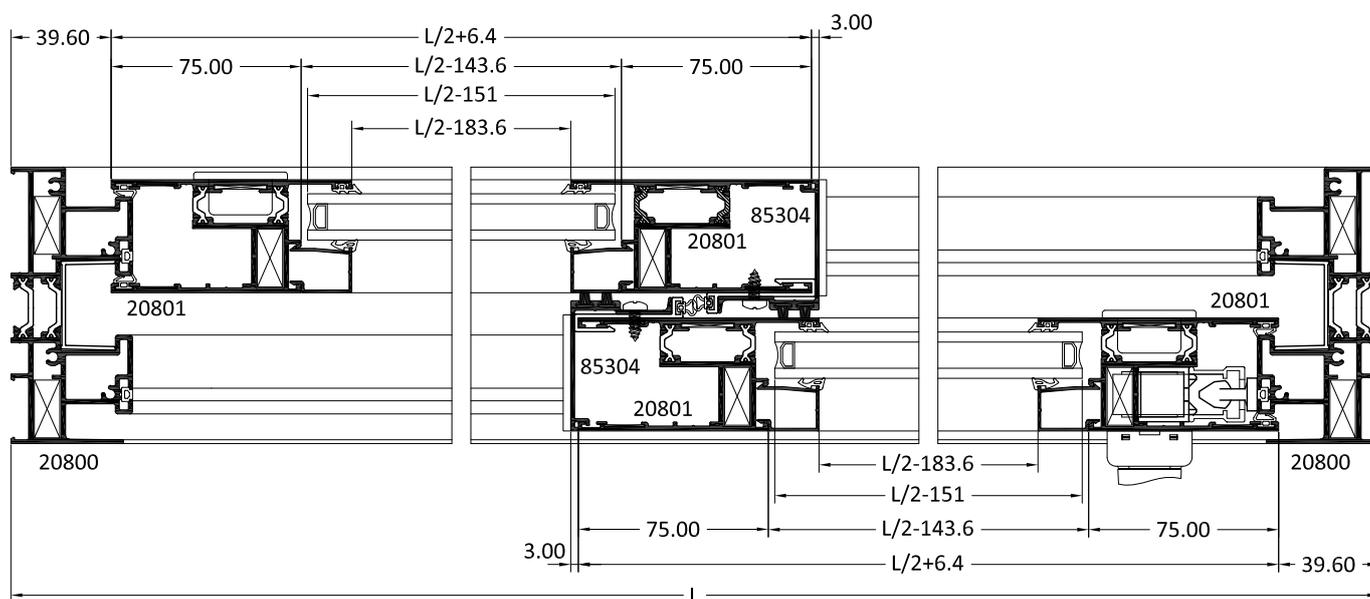

**LISTA DE CORTE. PUERTA DE DOS HOJAS. UNA HOJA FIJA Y UNA HOJA ELEVABLE**
**LISTA DE CORTE**

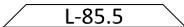
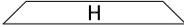
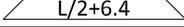
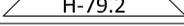
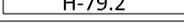
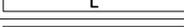
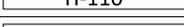
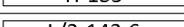
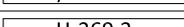
PERFIL	DENOMINACIÓN	UDS	CORTE
85305	Carril rodadura (sólo marco inferior)	2	
20800	Cerco perimetral horizontal	2	
20800	Cerco perimetral vertical	2	
20801	Hoja perimetral horizontal	4	
20801	Hoja perimetral vertical	4	
85304	Perfil de cruce	2	
3704	Visera	1	
3763	Tirador (opcional)	1-2	
3764	Base tirador (opcional)	1-2	
(*)	Junquillo (horizontal)	4	
(*)	Junquillo (vertical)	4	

(\*) Para la elección de junquillo consultar hoja de acristalamiento

**RELCIÓN DE HERRAJE Y ACCESORIOS**

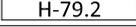
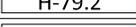
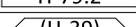
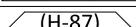
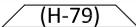
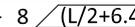
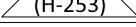
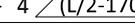
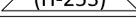
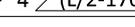
REFERENCIA	DENOMINACIÓN	UDS	CORTE
301135	Escuadra bloqueo para marco y hoja	16	
300054	Escuadra alineación exterior	8	
300161	Escuadra alineación 16x1	16	
301131	Engatillado de cruce	2	
301133	Junta de cierre para engatillado de cruce	2	
300395	Felpa 7x6 con lámina	4	
301130	U de marco	4	2  + 2 
301134	Perfil de cierre para canal	6	4  + 2 
301132	Junta elevable	12	4  + 8 
301084	Kit carros elevable 300 Kg	1	
301087	Calzo inferior cremona	1	
301088	Calzo para cremona	4	
301089	Bulón de cierre elevable	2	
301090	Tornillo para manilla M6x50	2	
301092	Tornillo 7982 - 4.8x60	7	
301093	Tornillo 7982 - 4.8x25	4	
301094	Tornillo 7982 - 4.8x32	4	
301095	Tornillo 7982 - 4.8x38	2	
(según color)	Manilla elevable recta	1	
(según color)	Tirador uñero exterior	1	
301078 301079 301080 301081	Cremona elevadora	1	Altura hoja 850 - 1270
			Altura hoja 1220 - 1850
			Altura hoja 1851 - 2350
			Altura hoja 2100 - 2750
301099 301100 301101 301102	Varilla de conexión	1	Ancho hoja 700 - 1600
			Ancho hoja 1601 - 1850
			Ancho hoja 1851 - 2350
			Ancho hoja 2351 - 3300
301103	Carro para hoja fija	2	
300593	Salida de agua con deflector	4-6	
300532	Junta de acristalamiento exterior	8	4  + 4 
(**)	Junta de acristalamiento interior	8	4  + 4 

(\*\*) Para la elección de la junta de acristalamiento interior consultar hoja de acristalamiento

LISTA DE CORTE. PUERTA DE DOS HOJAS. DOS HOJAS ELEVABLES

ALZADO

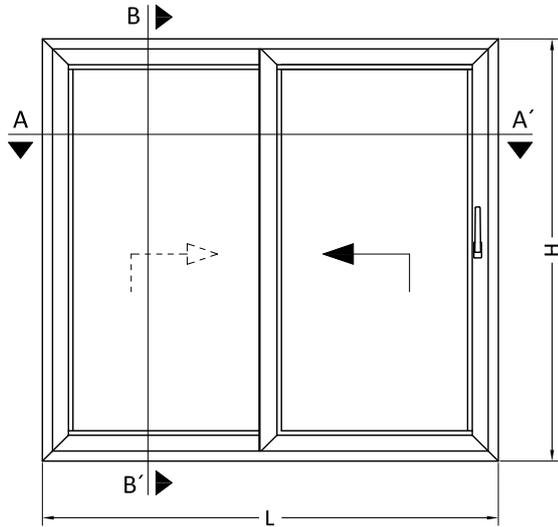

SECCIÓN VERTICAL B-B'

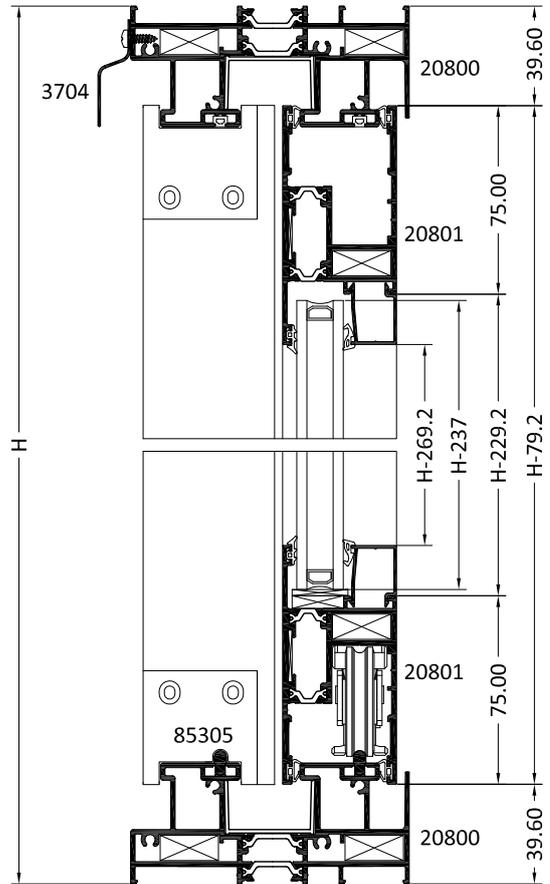

SECCIÓN HORIZONTAL A-A'

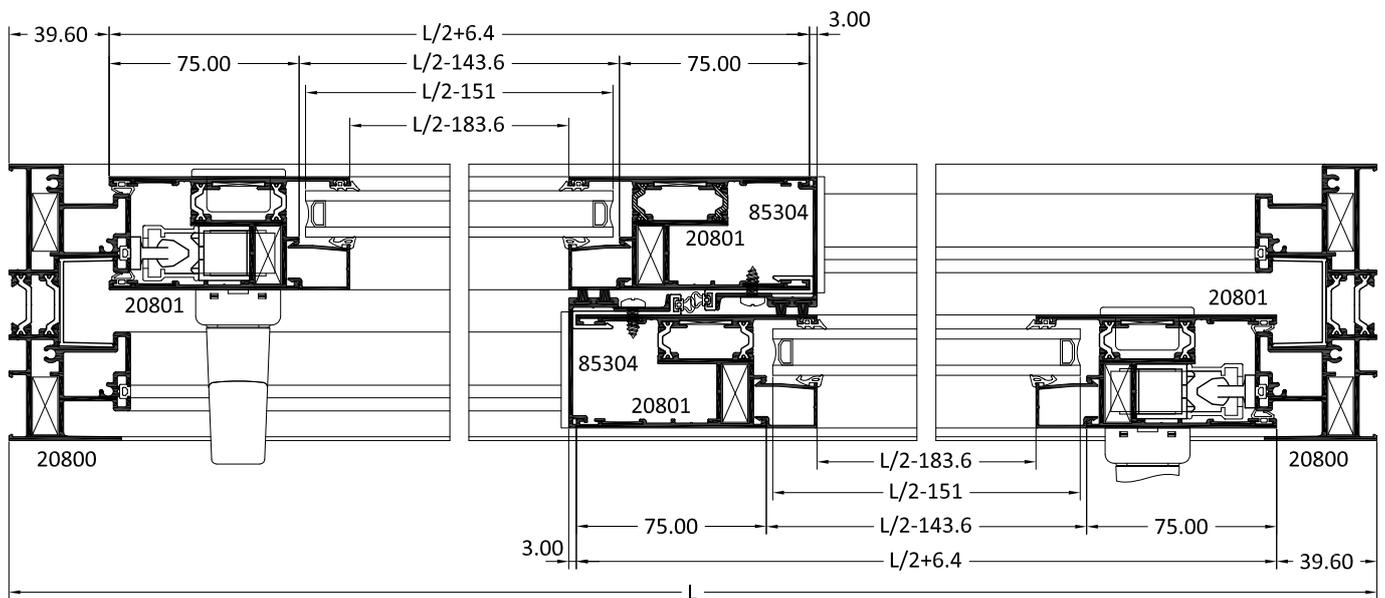

**LISTA DE CORTE. PUERTA DE DOS HOJAS. DOS HOJAS ELEVABLES**
**LISTA DE CORTE**

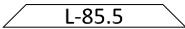
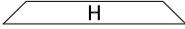
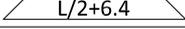
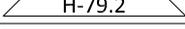
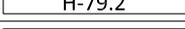
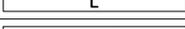
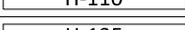
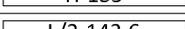
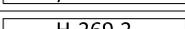
PERFIL	DENOMINACIÓN	UDS	CORTE
85305	Carril rodadura (sólo marco inferior)	2	
20800	Cerco perimetral horizontal	2	
20800	Cerco perimetral vertical	2	
20801	Hoja perimetral horizontal	4	
20801	Hoja perimetral vertical	4	
85304	Perfil de cruce	2	
3704	Visera	1	
3763	Tirador (opcional)	1-2	
3764	Base tirador (opcional)	1-2	
(*)	Junquillo (horizontal)	4	
(*)	Junquillo (vertical)	4	

(\*) Para la elección de junquillo consultar hoja de acristalamiento

**RELCIÓN DE HERRAJE Y ACCESORIOS**

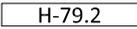
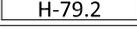
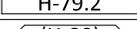
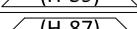
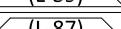
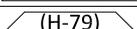
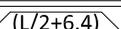
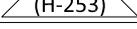
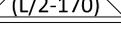
REFERENCIA	DENOMINACIÓN	UDS	CORTE
301135	Escuadra bloqueo para marco y hoja	16	
300054	Escuadra alineación exterior	8	
300161	Escuadra alineación 16x1	16	
301131	Engatillado de cruce	2	
301133	Junta de cierre para engatillado de cruce	2	
300395	Felpa 7x6 con lámina	4	
301130	U de marco	4	2  + 2 
301134	Perfil de cierre para canal	6	4  + 2 
301132	Junta elevable	12	4  + 8 
301084	Kit carros elevable 300 Kg	2	
301087	Calzo inferior cremona	2	
301088	Calzo para cremona	8	
301089	Bulón de cierre elevable	4	
301090	Tornillo para manilla M6x50	4	
301092	Tornillo 7982 - 4.8x60	14	
301093	Tornillo 7982 - 4.8x25	8	
301094	Tornillo 7982 - 4.8x32	8	
301095	Tornillo 7982 - 4.8x38	4	
(según color)	Manilla elevable recta	2	
(según color)	Tirador uñero exterior	2	
301078 301079 301080 301081	Cremona elevadora	2	Altura hoja 850 - 1270
			Altura hoja 1220 - 1850
			Altura hoja 1851 - 2350
			Altura hoja 2100 - 2750
301099 301100 301101 301102	Varilla de conexión	2	Ancho hoja 700 - 1600
			Ancho hoja 1601 - 1850
			Ancho hoja 1851 - 2350
			Ancho hoja 2351 - 3300
300593	Salida de agua con deflector	4-6	
300532	Junta de acristalamiento exterior	8	4  + 4 
(**)	Junta de acristalamiento interior	8	4  + 4 

(\*\*) Para la elección de la junta de acristalamiento interior consultar hoja de acristalamiento

LISTA DE CORTE. PUERTA DE TRES HOJAS. DOS HOJAS ELEVABLES Y UNA FIJA

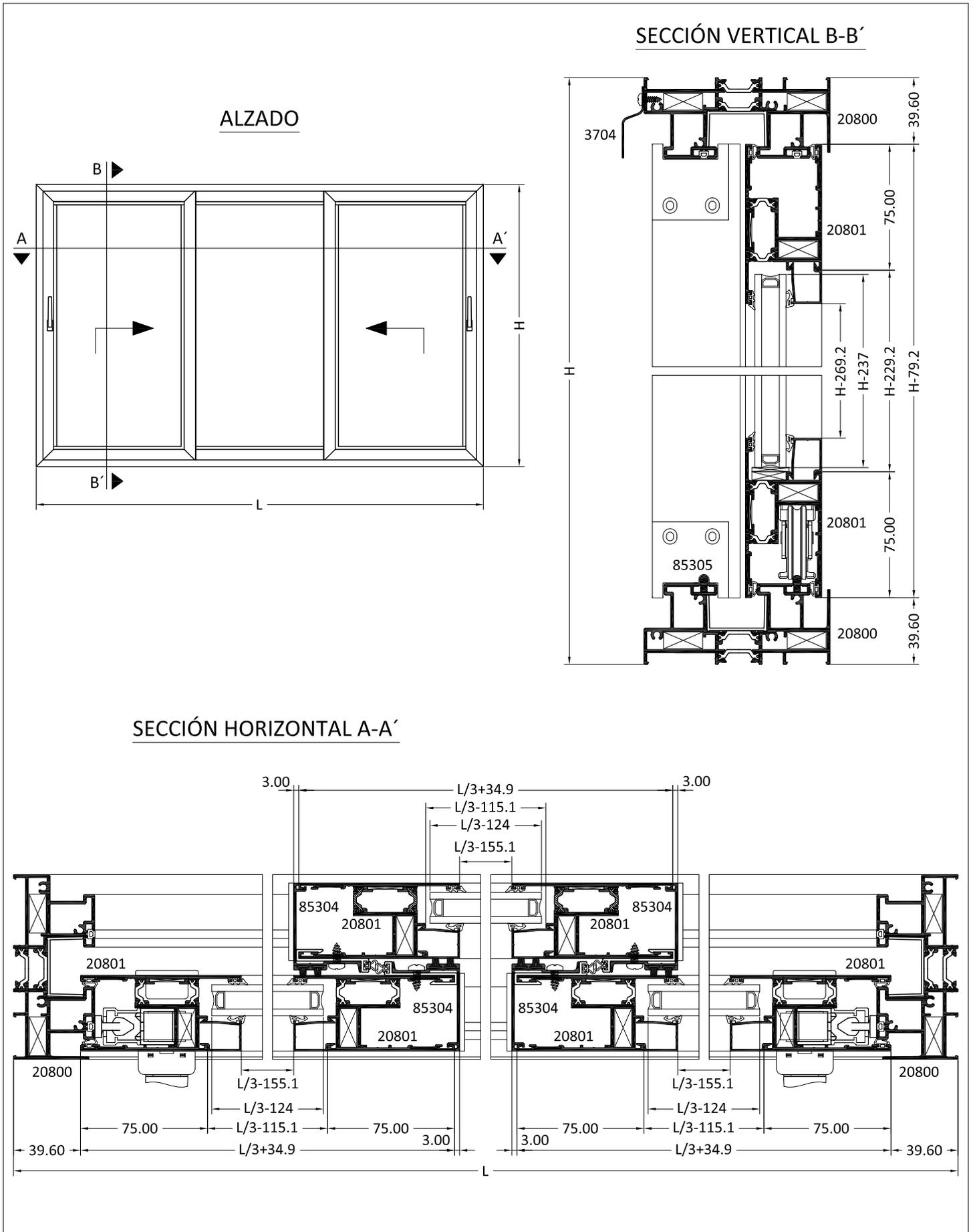

**LISTA DE CORTE. PUERTA DE TRES HOJAS. DOS HOJAS ELEVABLES Y UNA FIJA**

**LISTA DE CORTE**

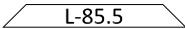
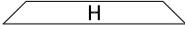
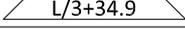
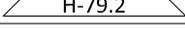
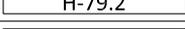
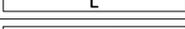
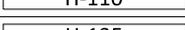
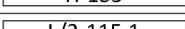
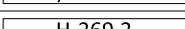
PERFIL	DENOMINACIÓN	UDS	CORTE
85305	Carril rodadura (sólo marco inferior)	2	
20800	Cerco perimetral horizontal	2	
20800	Cerco perimetral vertical	2	
20801	Hoja perimetral horizontal	6	
20801	Hoja perimetral vertical	6	
85304	Perfil de cruce	4	
3704	Visera	1	
3763	Tirador (opcional)	2-4	
3764	Base tirador (opcional)	2-4	
(*)	Junquillo (horizontal)	6	
(*)	Junquillo (vertical)	6	

(\*) Para la elección de junquillo consultar hoja de acristalamiento

**RELCIÓN DE HERRAJE Y ACCESORIOS**

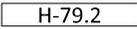
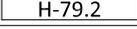
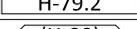
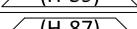
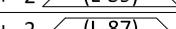
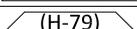
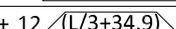
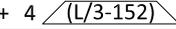
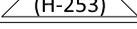
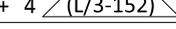
REFERENCIA	DENOMINACIÓN	UDS	CORTE
301135	Escuadra bloqueo para marco y hoja	16	
300054	Escuadra alineación exterior	12	
300161	Escuadra alineación 16x1	16	
301131	Engatillado de cruce	4	
301133	Junta de cierre para engatillado de cruce	4	
300395	Felpa 7x6 con lámina	8	
301130	U de marco	4	2  + 2 
301134	Perfil de cierre para canal	6	4  + 2 
301132	Junta elevable	16	4  + 12 
301084	Kit carros elevable 300 Kg	2	
301087	Calzo inferior cremona	2	
301088	Calzo para cremona	8	
301089	Bulón de cierre elevable	4	
301090	Tornillo para manilla M6x50	4	
301092	Tornillo 7982 - 4.8x60	14	
301093	Tornillo 7982 - 4.8x25	8	
301094	Tornillo 7982 - 4.8x32	8	
301095	Tornillo 7982 - 4.8x38	4	
(según color)	Manilla elevable recta	2	
(según color)	Tirador uñero exterior	2	
301078 301079 301080 301081	Cremona elevadora	2	Altura hoja 850 - 1270
			Altura hoja 1220 - 1850
			Altura hoja 1851 - 2350
			Altura hoja 2100 - 2750
301099 301100 301101 301102	Varilla de conexión	2	Ancho hoja 700 - 1600
			Ancho hoja 1601 - 1850
			Ancho hoja 1851 - 2350
			Ancho hoja 2351 - 3300
300593	Salida de agua con deflector	4-6	
301103	Carro para hoja fija	2	
300532	Junta de acristalamiento exterior	10	6  + 4 
(**)	Junta de acristalamiento interior	10	6  + 4 

(\*\*) Para la elección de la junta de acristalamiento interior consultar hoja de acristalamiento



**LISTA DE CORTE. PUERTA DE CUATRO HOJAS. DOS HOJAS ELEVABLES Y DOS FIJAS**

**LISTA DE CORTE**

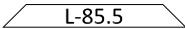
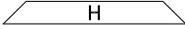
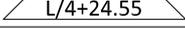
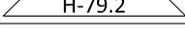
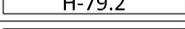
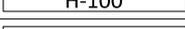
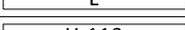
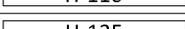
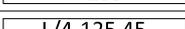
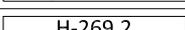
PERFIL	DENOMINACIÓN	UDS	CORTE
85305	Carril rodadura (sólo marco inferior)	2	
20800	Cerco perimetral horizontal	2	
20800	Cerco perimetral vertical	2	
20801	Hoja perimetral horizontal	8	
20801	Hoja perimetral vertical	8	
85304	Perfil de cruce	4	
----	Unión de cuatro hojas	1	
3704	Visera	1	
3763	Tirador (opcional)	2-6	
3764	Base tirador (opcional)	2-6	
(*)	Junquillo (horizontal)	8	
(*)	Junquillo (vertical)	8	

(\*) Para la elección de junquillo consultar hoja de acristalamiento

**RELCIÓN DE HERRAJE Y ACCESORIOS**

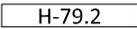
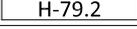
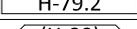
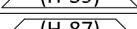
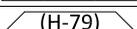
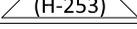
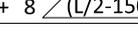
REFERENCIA	DENOMINACIÓN	UDS	CORTE
301135	Escuadra bloqueo para marco y hoja	20	
300054	Escuadra alineación exterior	16	
300161	Escuadra alineación 16x1	32	
301131	Engatillado de cruce	4	
301133	Junta de cierre para engatillado de cruce	4	
300395	Felpa 7x6 con lámina	8	
301130	U de marco	4	2  + 2 
301134	Perfil de cierre para canal	6	4  + 2 
301132	Junta elevable	12	6  + 16 
301084	Kit carros elevable 300 Kg	2	
301087	Calzo inferior cremona	2	
301088	Calzo para cremona	8	
301089	Bulón de cierre elevable	4	
301090	Tornillo para manilla M6x50	4	
301092	Tornillo 7982 - 4.8x60	14	
301093	Tornillo 7982 - 4.8x25	8	
301094	Tornillo 7982 - 4.8x32	8	
301095	Tornillo 7982 - 4.8x38	4	
(según color)	Manilla elevable recta	2	
(según color)	Tirador uñero exterior	2	
301078 301079 301080 301081	Cremona elevadora	2	Altura hoja 850 - 1270
			Altura hoja 1220 - 1850
			Altura hoja 1851 - 2350
			Altura hoja 2100 - 2750
301099 301100 301101 301102	Varilla de conexión	2	Ancho hoja 700 - 1600
			Ancho hoja 1601 - 1850
			Ancho hoja 1851 - 2350
			Ancho hoja 2351 - 3300
300593	Salida de agua con deflector	4-6	
301103	Carro para hoja fija	4	
300532	Junta de acristalamiento exterior	16	8  + 8 
(**)	Junta de acristalamiento interior	16	8  + 8 

(\*\*) Para la elección de la junta de acristalamiento interior consultar hoja de acristalamiento